

TECHNICAL MANUAL

Air-cooled Rooftop Package Air Conditioner

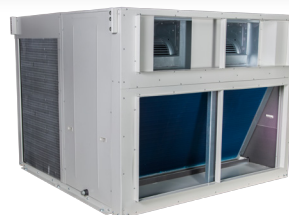
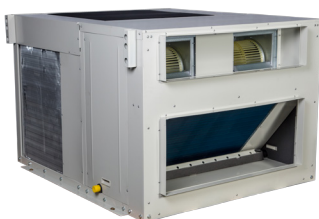

Contents

Product Nomenclature	2
Features	4
Engineering Specifications	5
General Data	5
Electrical Data	7
Operating Range	8
Sound Pressure Level	9
Fan Performance Curve	10
Dimensions	13
Wiring Diagrams	15
Installation	18
Instruction For Use	22
Troubleshooting	24
Exploded View And Parts List	25
Conversion Table	28

Air-cooled Rooftop Package Air Conditioner

YRT8 - 32ACY2 (R22)
YRT8 - 32ACY4 (R407C)

Product Nomenclature

Air-cooled Rooftop Indoor Unit

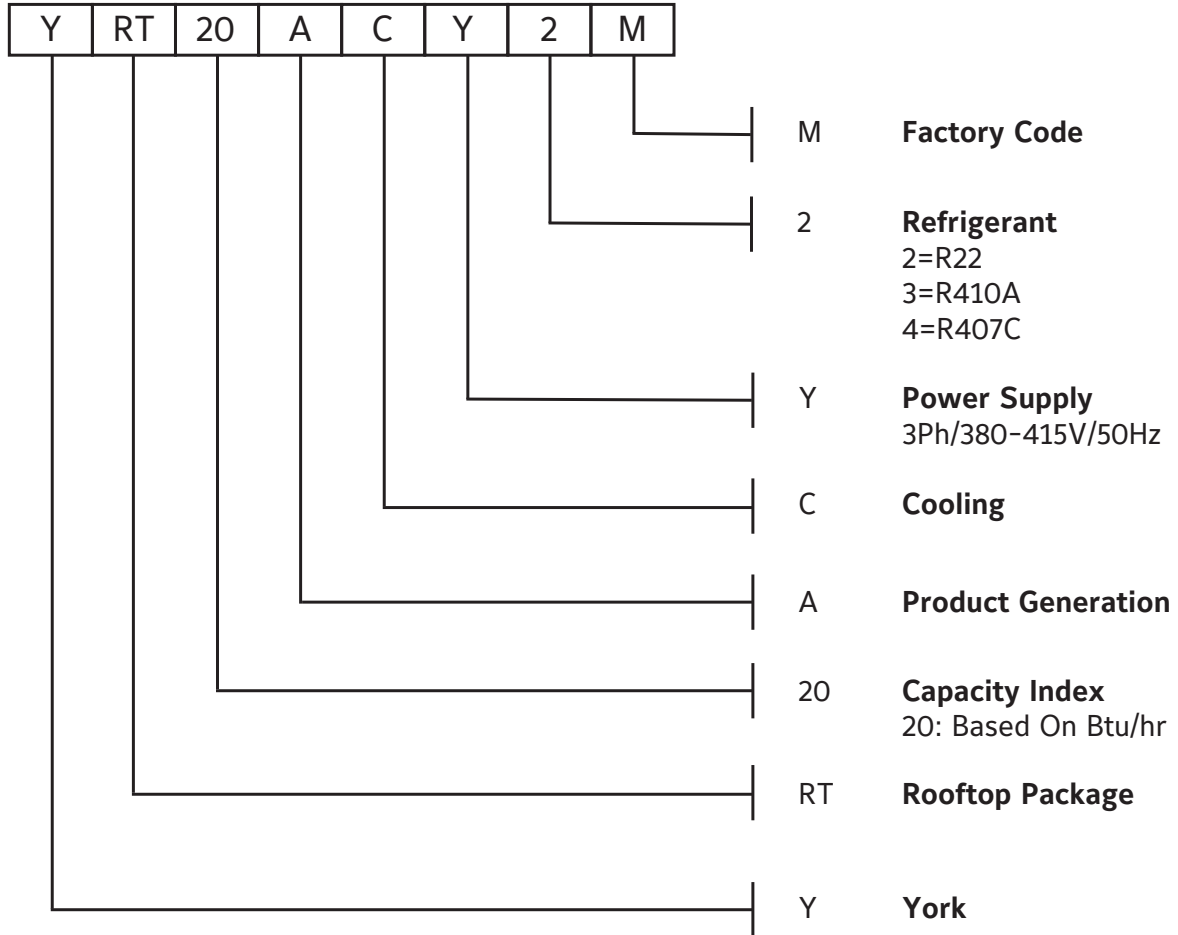

Typical Installation Example

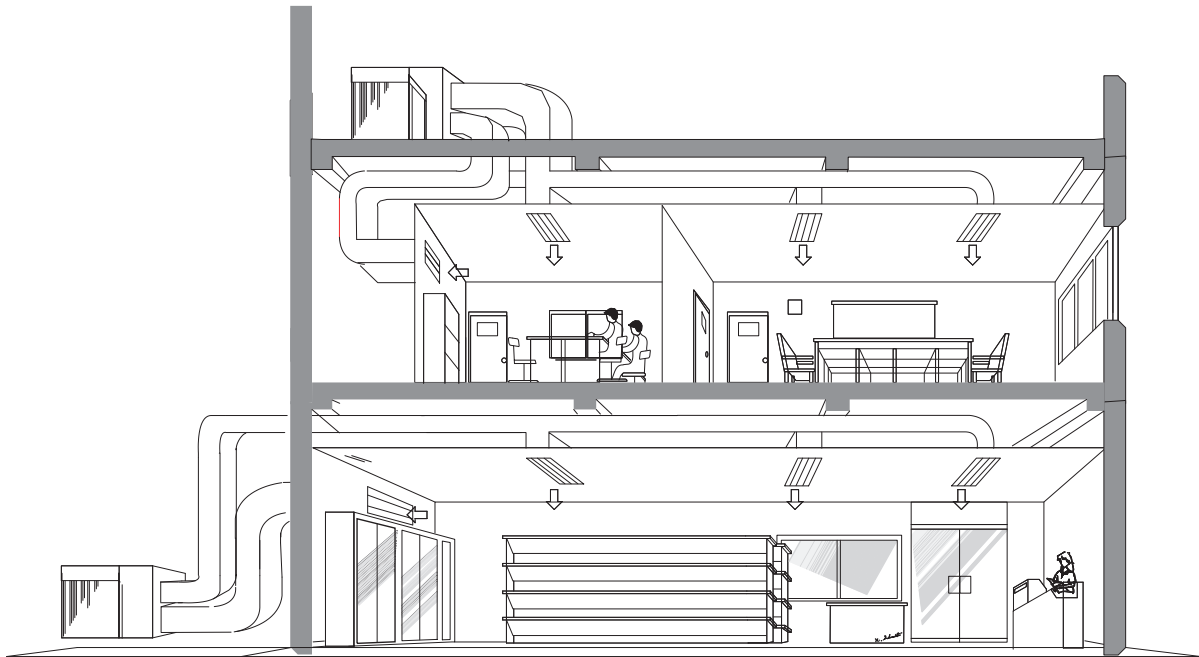

Features

Compact Construction Design

Compact and rigid single unit construction design provides convenient installation with no additional piping work as both indoor and outdoor sides are pre-connected. The unit casing is made of external painted sheet metal that is suitable for outdoor application. The unique feature of unit's flat top design allows unit to be stacked up and provides maximum usage of warehouse and container space.

Single Capacity Control

Unit is equipped with Scroll Compressor that is more reliable with higher efficiency. The compressor is mounted on rubber vibration isolators for minimal noise level and vibration transmissions.

人 - Δ Indoor Fan Motor

Direct-drive, forward curved, centrifugal-type fans are used to deliver an accurate air flow at low noise level.
The standard unit fan motor is Δ connection.
Unit can be operated at lower air flow by changing to 人 connection.

High Sensible Cooling Capacity

The sensible cooling capacity has been significantly improved through balanced optimized heat exchanger design.

Control

Mechanical control allows the air conditioner to operate as standalone system, and allows to be connected to any BMS.

Engineering Specifications

General Data Cooling Only

Model name	YRT	8ACY2	10ACY2	12ACY2	15ACY2	20ACY2	24ACY2	32ACY2	
Power supply		3Ph~380-415V 50Hz							
Total cooling capacity	Outdoor 35°CDB	kW	24.0	32.0	35.0	48.0	64.0	70.0	100.0
		Btu/h	81,900	109,200	119,500	163,800	218,400	238,900	341,200
	Outdoor 46°CDB	kW	21.9	30.8	33.0	43.7	61.5	66.0	94.0
		Btu/h	74,800	105,100	112,600	149,200	209,900	225,200	320,800
Sensible cooling capacity	Outdoor 35°CDB	kW	19.2	25.6	28.0	38.4	51.2	56.0	80.0
		Btu/h	65,600	87,400	95,600	131,100	174,700	191,100	273,000
Capacity step	%	0-100			0-50-100			0-66-100	
Refrigerant	R-22								
Refrigerant charge	kg	4.0	5.9	5.7	2x4.5	2x5.9	2x5.7	3x3.5	
Refrigerant control	Capillary Tube								
External finish	Acrylic Resin Coating								
Color	MUNSELL 5Y8/1								
Dimension	Height	mm	1,000			1,200		1,650	
	Width	mm	1,300			1,990		2,100	
	Depth	mm	1,530			1,670		2,100	
Net weight	kg	360	390	395	655	755	765	1,100	
Compressor	Hermetic Line Start								
No. x Motor output	kW	1x5.5	1x7.5	1x8.0	2x5.5	2x7.5	2x8.0	3x8.0	
Evaporator	Cross Fin Coil								
Evaporator fan	Centrifugal - Direct-Drive								
Evaporator fan motor	Three - Phase Squirrel Cage Induction Motor (Δ-Δ Connection)								
No. x Motor output	kW	1x0.7	1x1.25	1x1.25	1x1.7	1x2.5	1x2.5	1x4.5	
Evaporator fan airflow	CMH	4,800	6,000	6,000	9,600	12,000	12,000	17,100	
	CFM	2,826	3,532	3,532	5,651	7,064	7,064	10,066	
External static pressure	mmAq	10			20		25		
	Pa	100			200		250		
Condenser	Cross Fin Coil								
Condenser fan	Propeller - Direct Drive								
Condenser fan motor	Three Phase Cage Induction Motor								
Condenser fan air flow	CMH	9,600		10,800	19,200		21,600	28,800	
	CFM	5,651		6,354	11,302		12,708	16,954	
Drain connection	mm	25.4							
Sound pressure level	dB(A)	66		69	70		73	76	
Protection devices	High Pressure Switch, Fuse Over Current Relay (Compressor) Internal Thermostat (Compressor,Outdoor&Indoor Fan Motor)								

- Note :**
- Cooling capacity is based on the following conditions.
Indoor;27°CDB,19°CWB, Outdoor;35°CDB
 - Refrigerant charge volumes are factory charged.
 - Capacity is gross capacity which do not include a deduction for evaporator fan motor heat.
 - The measuring point of the Sound pressure level is 1m from the unit surface.
 - The range of working voltage is within ±10% voltage of power supply.
 - Specification subject to change without notice.
 - Full refrigerant charge of YRT32 is 3x6.3Kg.

Engineering Specifications

General Data - Cooling Only

Model name	YRT	8ACY4	10ACY4	12ACY4	15ACY4	20ACY4	24ACY4	32ACY4	
Power supply		3Ph~380-415V 50Hz							
Total cooling capacity	Outdoor 35°CDB	kW	24.0	30.0	35.0	48.0	64.0	70.0	100.0
		Btu/h	81,900	102,400	119,500	163,800	218,400	238,900	341,200
	Outdoor 46°CDB	kW	21.9	28.8	33.0	43.7	61.5	66.0	94.0
		Btu/h	74,800	98,300	112,600	149,200	209,900	225,200	320,800
Sensible cooling capacity	Outdoor 35°CDB	kW	19.2	24.0	28.0	38.4	51.2	56.0	80.0
		Btu/h	65,600	81,900	95,600	131,100	174,700	191,100	273,000
Capacity step	%	0-100			0-50-100			0-66-100	
Refrigerant		R407C							
Refrigerant charge	kg	4.5	5.9	5.7	2x4.8	2x5.9	2x5.7	3x3.5	
Refrigerant control		Capillary Tube							
External finish		Acrylic Resin Coating							
Color		MUNSELL 5Y8/1							
Dimension	Height	mm	1,000			1,200		1,650	
	Width	mm	1,300			1,990		2,100	
	Depth	mm	1,530			1,670		2,100	
Net weight	kg	360	390	395	655	755	765	1,100	
Compressor		Hermetic Scroll							
No. x Motor output	kW	1x5.5	1x7.5	1x8.0	2x5.5	2x7.5	2x8.0	3x8.0	
Evaporator		Cross Fin Coil							
Evaporator fan		Centrifugal - Direct-Drive							
Evaporator fan motor		Three - Phase Squirrel Cage Induction Motor (Δ -Δ Connection)							
No. x Motor output	kW	1x0.7	1x1.25		1x1.7	1x2.5		1x4.5	
Evaporator fan airflow	CMH	5,400	6,000		9,000	12,000		17,100	
	CFM	3,179	3,532		5,300	7,064		10,066	
External static pressure	mmAq	10			20		25		
	Pa	100			200		250		
Condenser		Cross Fin Coil							
Condenser fan		Propeller - Direct Drive							
Condenser fan motor		Three Phase Cage Induction Motor							
Condenser fan air flow	CMH	9,600		10,800	19,200		21,600	28,800	
	CFM	5,651		6,354	11,302		12,708	16,954	
Drain connection	mm	25.4							
Sound pressure level	dB(A)	66		69	70		73	76	
Protection devices		High Pressure Switch, Fuse, Low Pressure Switch(Only YRT-32), Over Current Relay (Compressor) Internal Thermostat (Compressor, Outdoor&Indoor Fan Motor)							

- Note :**
- Cooling capacity is based on the following conditions.
Indoor;27°CDB,19°CWB, Outdoor;35°CDB
 - Refrigerant charge volumes are factory charged.
 - Capacity is gross capacity which do not include a deduction for evaporator fan motor heat.
 - The measuring point of the Sound pressure level is 1m from the unit surface.
 - The range of working voltage is within ±10% voltage of power supply.
 - Specification subject to change without notice.
 - Full refrigerant charge of YRT32 is 3x6.3Kg.

Electrical Data

VOLT	ITEM		YRT8A	YRT10A	YRT12A	YRT15A
			Cooling	Cooling	Cooling	Cooling
415V	TOTAL INPUT	kW	8.1	10.5	12.5	15.6
	TOTAL RUN CURRENT	A	13.4	16.9	20.2	25.3
	POWER FACTOR	%	84%	86%	86%	86%
	START CURRENT	A	91.3	119.3	119.6	103.5
	COMPRESSOR INPUT	kW	6.4	8.1	9.3	12.4
	RUN CURRENT	A	9.1	12.1	14.6	17.6
	Outdoor FAN INPUT	kW	0.5	0.5	1.3	1.0
	RUN CURRENT	A	1.5	1.3	2.1	2.8
	Indoor FAN INPUT	kW	1.2	1.9	1.9	2.2
RUN CURRENT	A	2.8	3.5	3.5	4.9	
400V	TOTAL INPUT	kW	8.1	10.5	12.5	15.6
	TOTAL RUN CURRENT	A	13.9	17.6	21.0	26.2
	POWER FACTOR	%	84%	86%	86%	86%
	START CURRENT	A	94.8	123.7	114.8	107.4
	COMPRESSOR INPUT	kW	6.4	8.1	9.3	12.4
	RUN CURRENT	A	9.4	12.7	15.2	18.2
	Outdoor FAN INPUT	kW	0.5	0.5	1.3	1.0
	RUN CURRENT	A	1.6	1.3	2.2	2.9
	Indoor FAN INPUT	kW	1.2	1.9	1.9	2.2
RUN CURRENT	A	2.9	3.6	3.6	5.1	
380V	TOTAL INPUT	kW	8.1	10.5	12.5	15.6
	TOTAL RUN CURRENT	A	14.6	18.5	22.1	27.6
	POWER FACTOR	%	84%	86%	86%	86%
	START CURRENT	A	99.6	130.2	110.1	113.1
	COMPRESSOR INPUT	kW	6.4	8.1	9.3	12.4
	RUN CURRENT	A	10.0	13.3	16.0	19.1
	Outdoor FAN INPUT	kW	0.5	0.5	1.3	1.0
	RUN CURRENT	A	1.6	1.4	2.3	3.1
	Indoor FAN INPUT	kW	1.2	1.9	1.9	2.2
RUN CURRENT	A	3.0	3.8	3.8	5.4	

VOLT	ITEM		YRT20A	YRT24A	YRT32A
			Cooling	Cooling	Cooling
415V	TOTAL INPUT	kW	20.8	25.5	39.8
	TOTAL RUN CURRENT	A	34.8	42.7	66.7
	POWER FACTOR	%	83%	83%	83%
	START CURRENT	A	136.5	140.8	164.2
	COMPRESSOR INPUT	kW	16.2	19.3	32.5
	RUN CURRENT	A	25.5	31.8	49.5
	Outdoor FAN INPUT	kW	1.0	2.6	2.7
	RUN CURRENT	A	2.6	4.2	5.6
	Indoor FAN INPUT	kW	3.6	3.6	4.6
RUN CURRENT	A	6.7	6.7	11.6	
400V	TOTAL INPUT	kW	20.8	25.5	39.8
	TOTAL RUN CURRENT	A	36.1	44.3	69.2
	POWER FACTOR	%	83%	83%	83%
	START CURRENT	A	141.7	136.9	161.1
	COMPRESSOR INPUT	kW	16.2	19.3	32.5
	RUN CURRENT	A	26.4	32.9	51.4
	Outdoor FAN INPUT	kW	1.0	2.6	2.7
	RUN CURRENT	A	2.7	4.4	5.8
	Indoor FAN INPUT	kW	3.6	3.6	4.6
RUN CURRENT	A	7.0	7.0	12.0	
380V	TOTAL INPUT	kW	20.8	25.5	39.8
	TOTAL RUN CURRENT	A	38.0	46.7	72.8
	POWER FACTOR	%	83%	83%	83%
	START CURRENT	A	149.1	133.4	158.8
	COMPRESSOR INPUT	kW	16.2	19.3	32.5
	RUN CURRENT	A	27.8	34.7	54.0
	Outdoor FAN INPUT	kW	1.0	2.6	2.7
	RUN CURRENT	A	2.8	4.6	6.1
	Indoor FAN INPUT	kW	3.6	3.6	4.6
RUN CURRENT	A	7.4	7.4	12.7	

Operating Range

Cooling

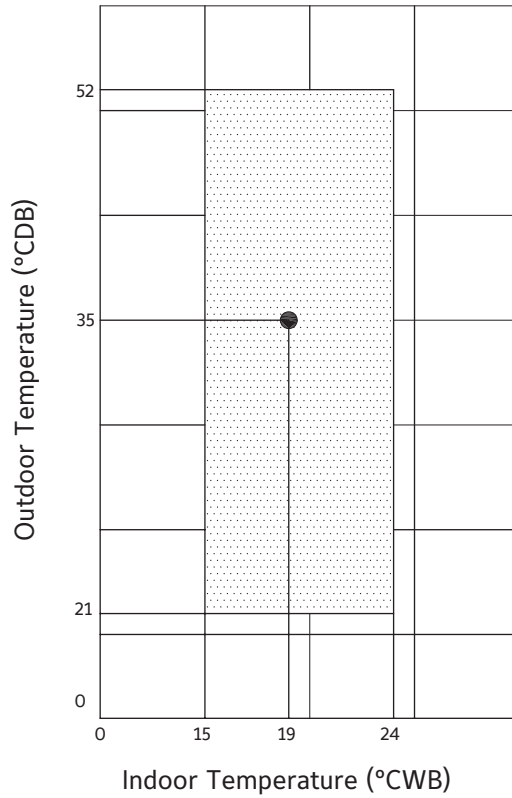

System Schematic Diagram

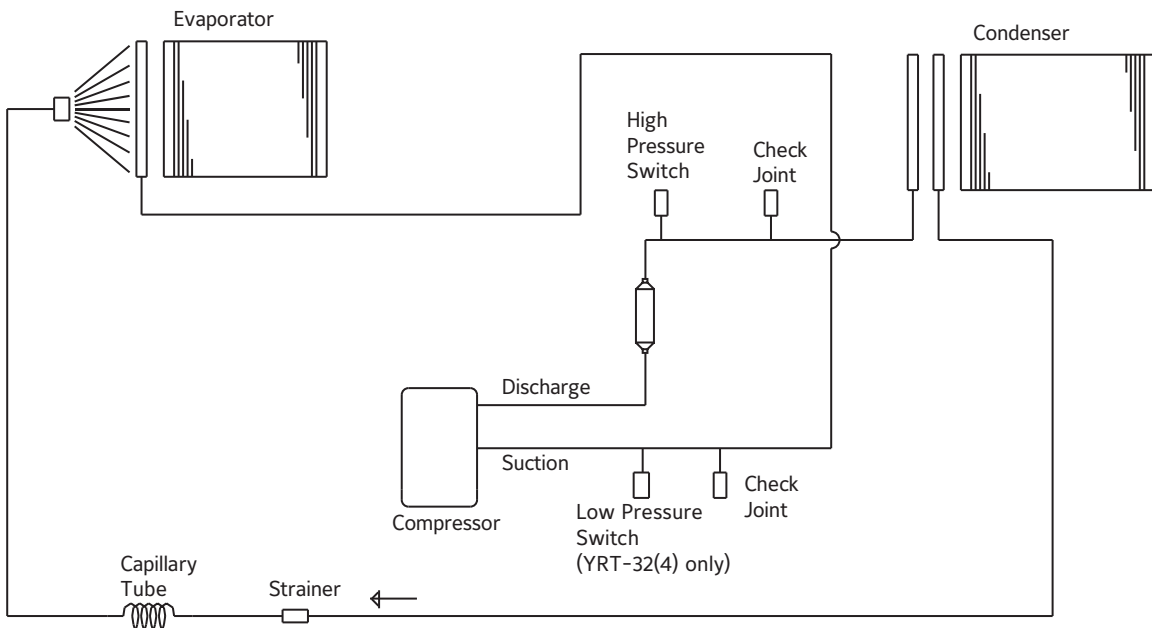

Sound Pressure Level

50Hz Sound Pressure Levels (SPL) Condition : Cooling

Model	SPL dB(A)	63Hz	125Hz	250Hz	500Hz	1000Hz	2000Hz	4000Hz	8000Hz
YRT8A	66.0	64.5	67.5	64.5	64.0	62.0	54.0	48.5	39.0
YRT10A	66.0	64.5	68.5	67.0	64.0	59.5	56.0	51.0	41.5
YRT12A	69.0	72.5	71.0	68.0	66.5	65.0	60.0	53.5	44.5

(dB)

Note. The measuring point is 1m from the comp.service panel.

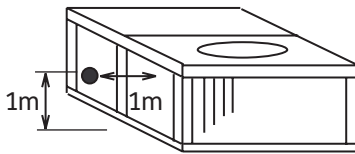

measuring place : open field

50Hz Sound Pressure Levels (SPL) Condition : Cooling

Model	SPL dB(A)	63Hz	125Hz	250Hz	500Hz	1000Hz	2000Hz	4000Hz	8000Hz
YRT15A	70.0	72.0	74.0	68.0	68.0	66.5	59.5	52.5	43.5
YRT20A	70.0	71.5	73.5	68.0	66.5	66.0	59.5	52.0	42.5
YRT24A	73.0	67.0	70.0	70.5	69.0	69.0	65.0	58.0	49.0
YRT32A	76.0	70.5	77.0	78.0	74.0	71.5	65.5	59.5	53.0

(dB)

Note. The measuring point is 1m from the comp.service panel.

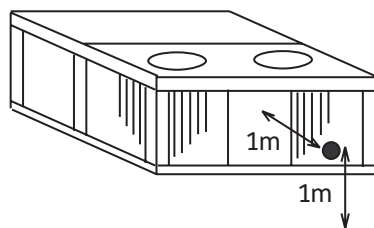

measuring place : open field

Fan Performance Curve

YRT8A

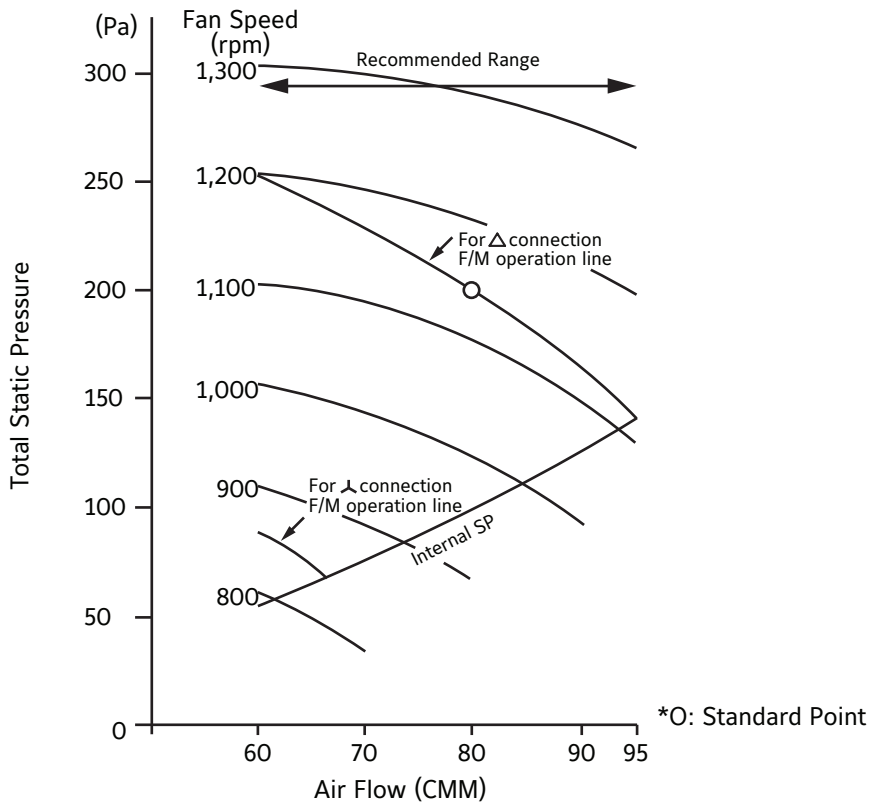

YRT10,12A

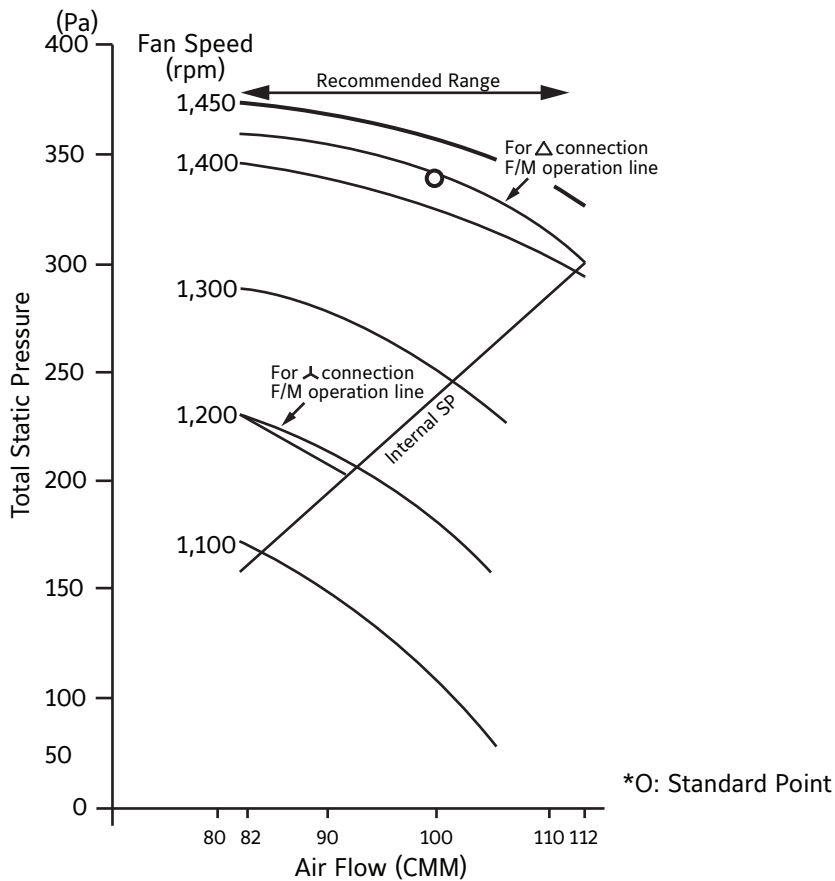

Fan Performance Curve

YRT15A

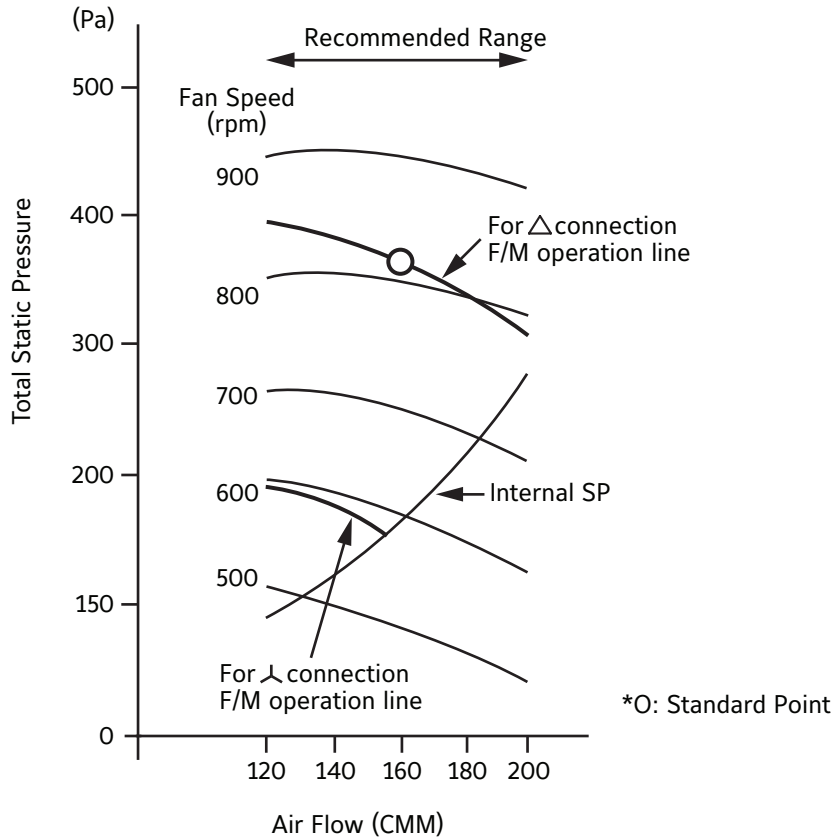

YRT20,24A

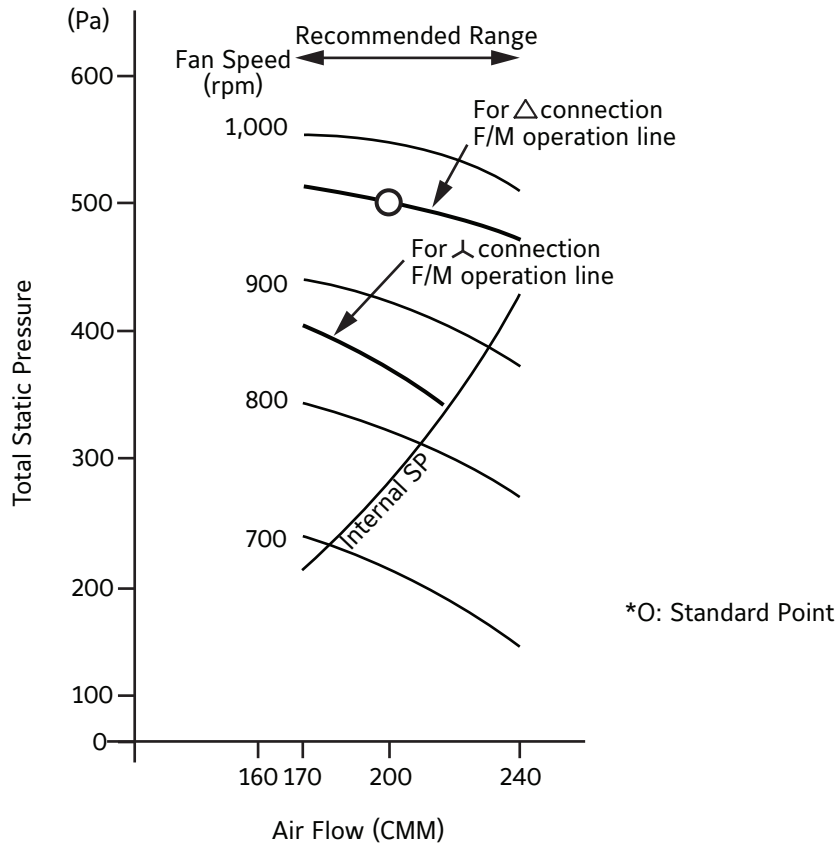

Fan Performance Curve

YRT32A

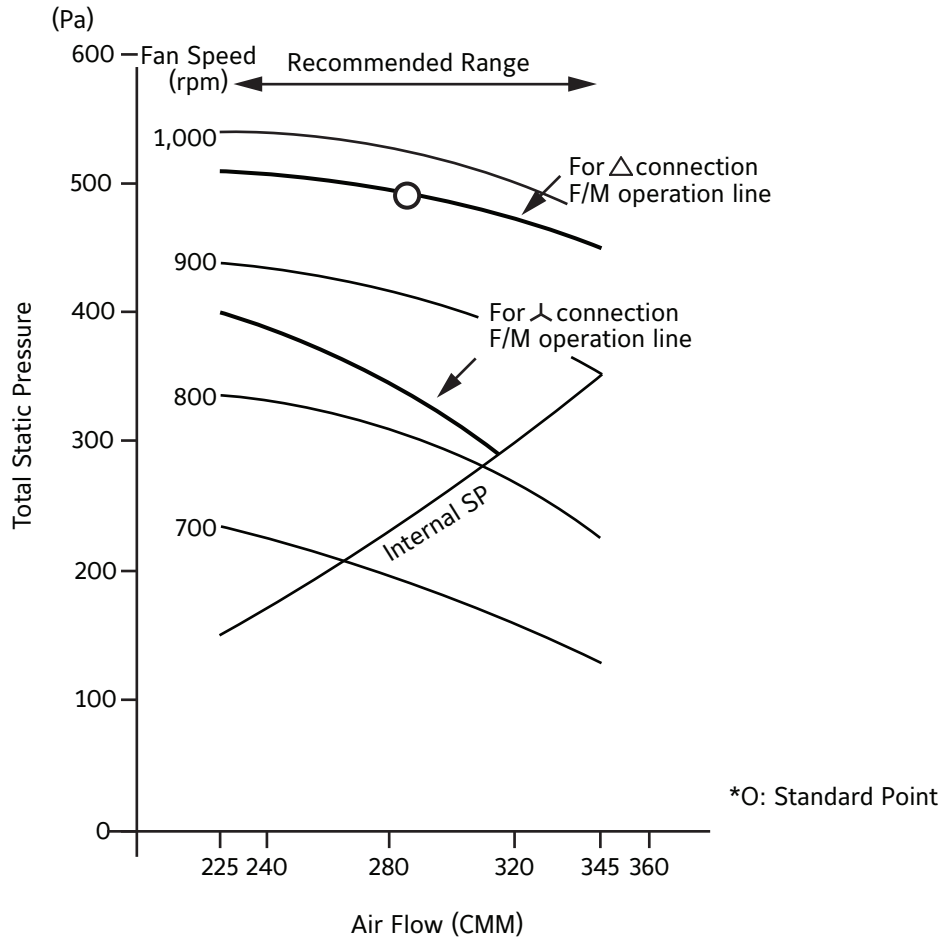

Dimensions

Model: YRT 8,10,12A

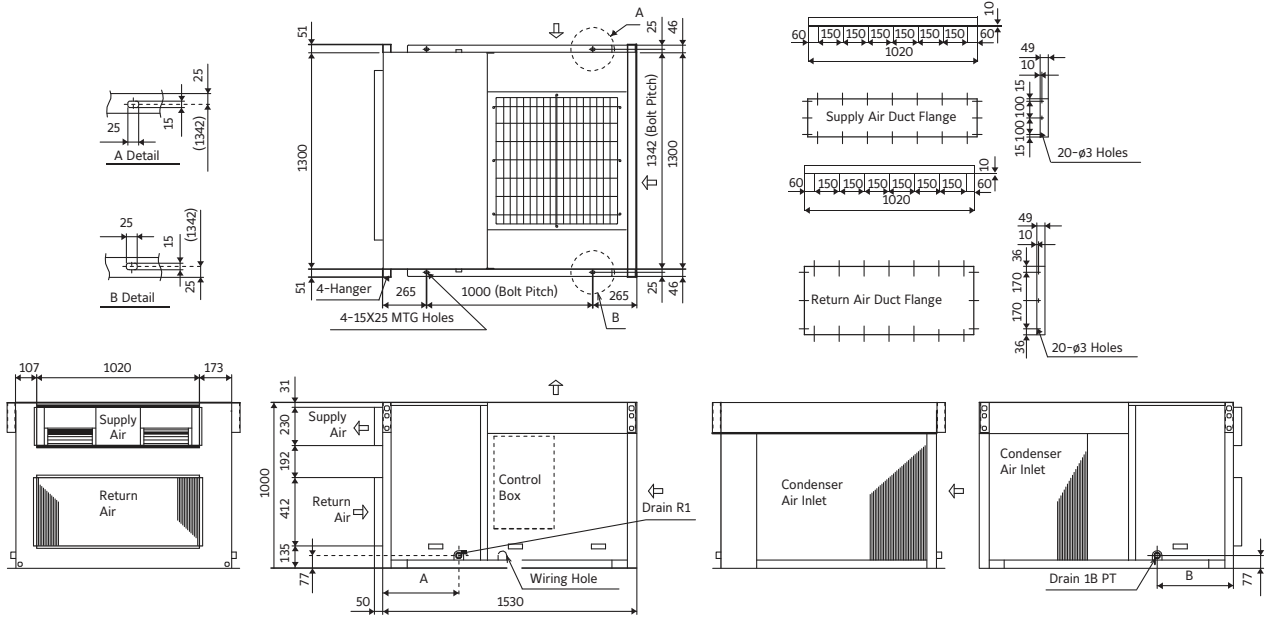

	A	B
YRT8,10A	437	437
YRT12A	458	458

[unit:mm]

Model: YRT 15,20,24A

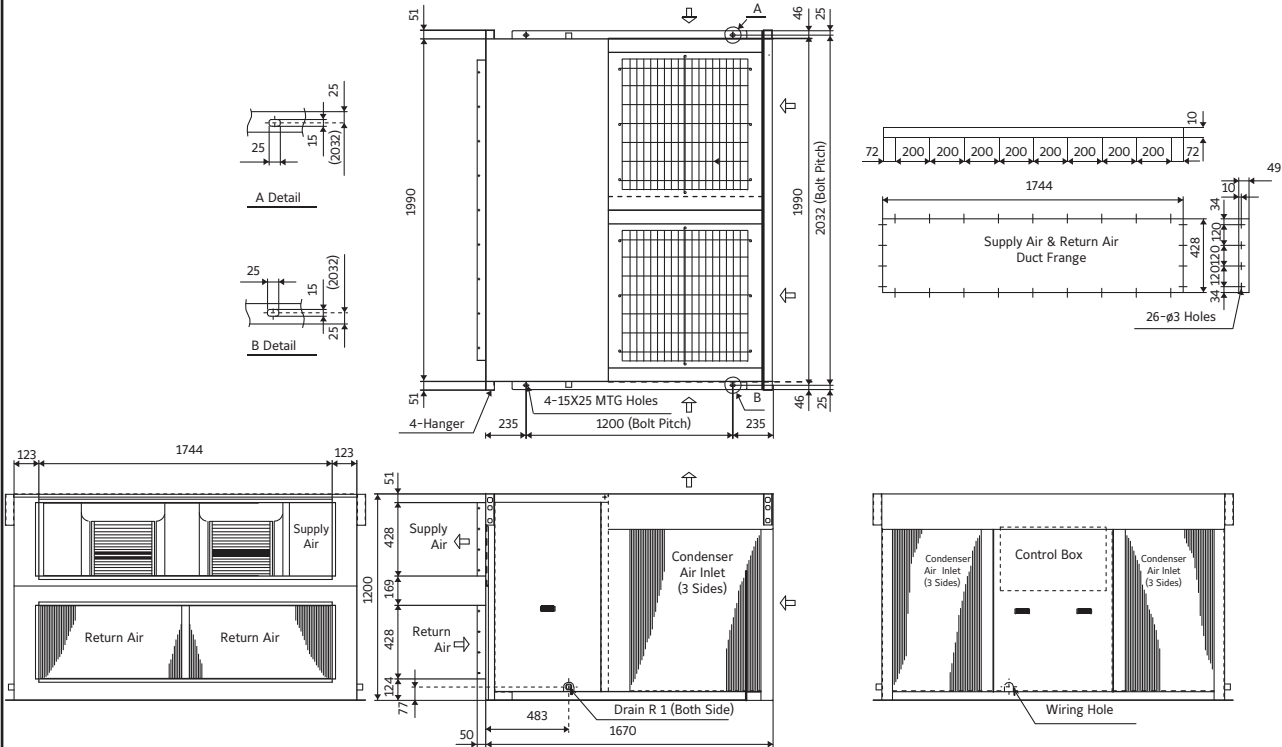

[unit:mm]

Dimensions

Model: YRT32A

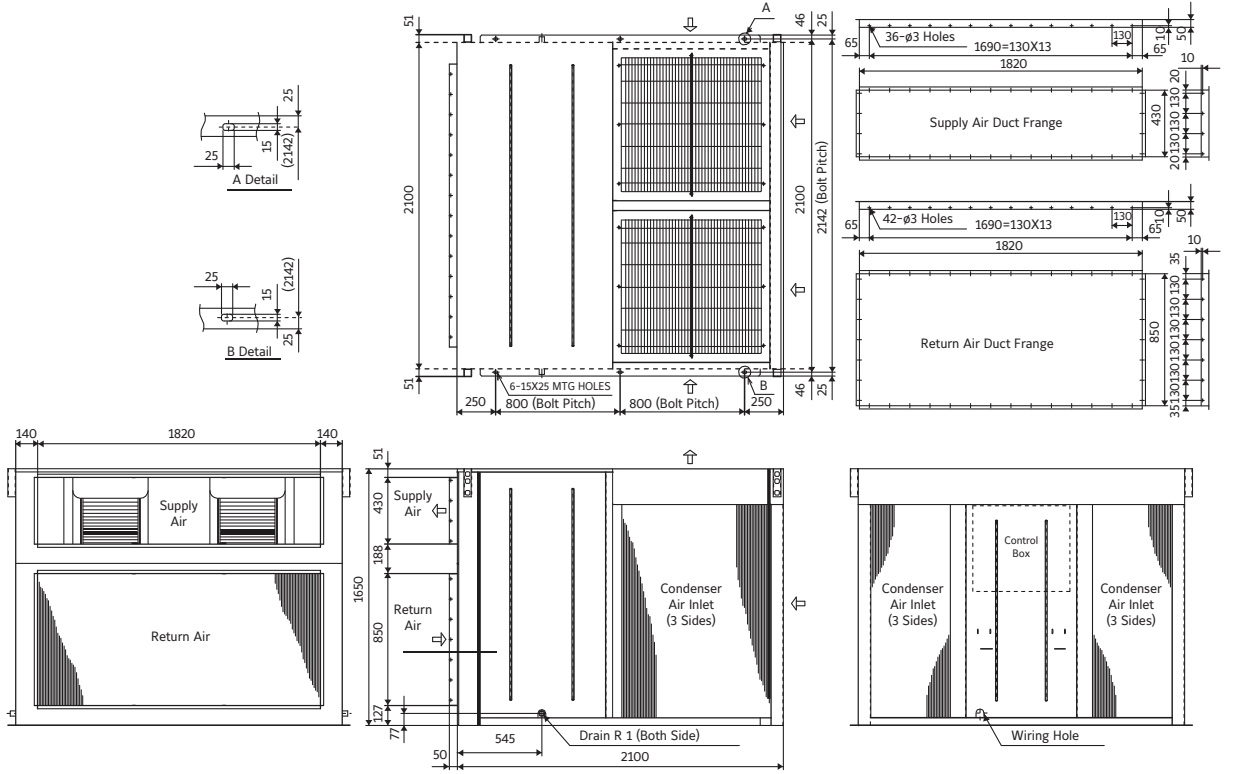

[unit:mm]

Wiring Diagram

Model: YRT8, 10, 12A

Symbol	Name	Symbol	Name	Symbol	Name
MC	Compressor Motor	Tr	Transformer	49F1	Internal Protector (Fan I/D)
MF1	Fan Motor (Indoor)	51C	Over Current Relay(Compressor)	49F2	Internal Protector (Fan O/D)
MF2	Fan Motor (Outdoor)	63H	High-Pressure Switch	<SW>	Switch (On)
52C	Contactor (Compressor)	63L	Low Pressure Switch	<23WA>	Thermostat (Room Temp.)
52F	Contactor (Fan I/D)	FZ	Auxiliary Relay (Fan)	C01-C04	Connector
TB1,2	Terminal Block	CZ	Auxiliary Relay (Compressor)	C11,12,14	
F1,F2	Fuse (3.15A)	30CZ,30FZ	Auxiliary Relay (Check)		

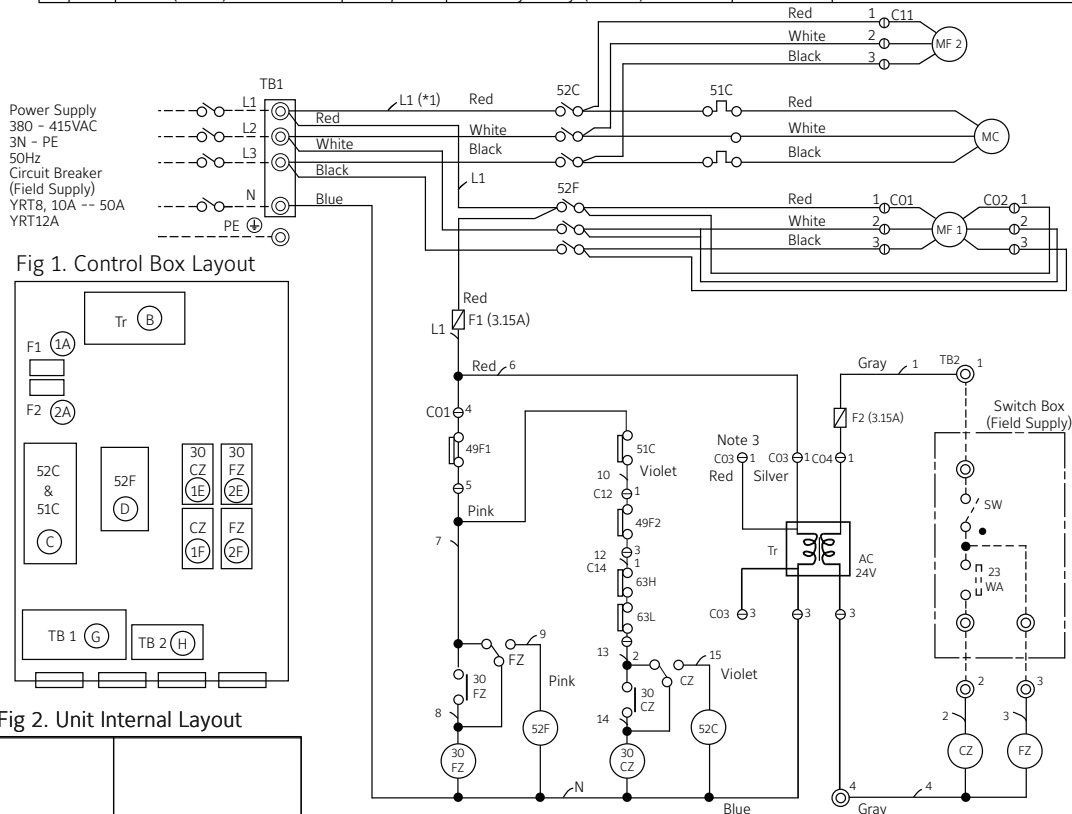
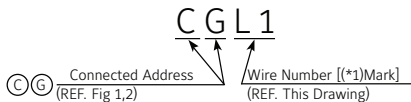
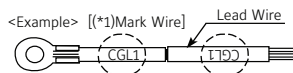

Fig 1. Control Box Layout

Fig 2. Unit Internal Layout

Note :

1. The dotted lines show field wiring.
2. The figure in the parenthesis show field supply parts.
3. In case of power supply 380VAC model (YRT8, 10, 12ACY4M)Tr wiring. Change the connector connection Tr, if 380VAC model is used for 400,415VAC and 400,415VAC model is used for 380VAC.
4. Refer below example about wiring mark.



Caution :

1. To protect compressor from abnormal current, over current relay <51C> is installed. Therefore, do not change factory set value of over current relay.

Controller Connection

Symbol	No.	Function	PAC-204RC (Option) Terminal No.
TB2	1	Power (Active)	24VAC(L)
	2	Cooling Operation	COMP1
	3	Fan Operation	FAN HI
	4	Power (Neutral)	24VAC(N)

Wiring Diagram

Model: YRT15, 20, 24A

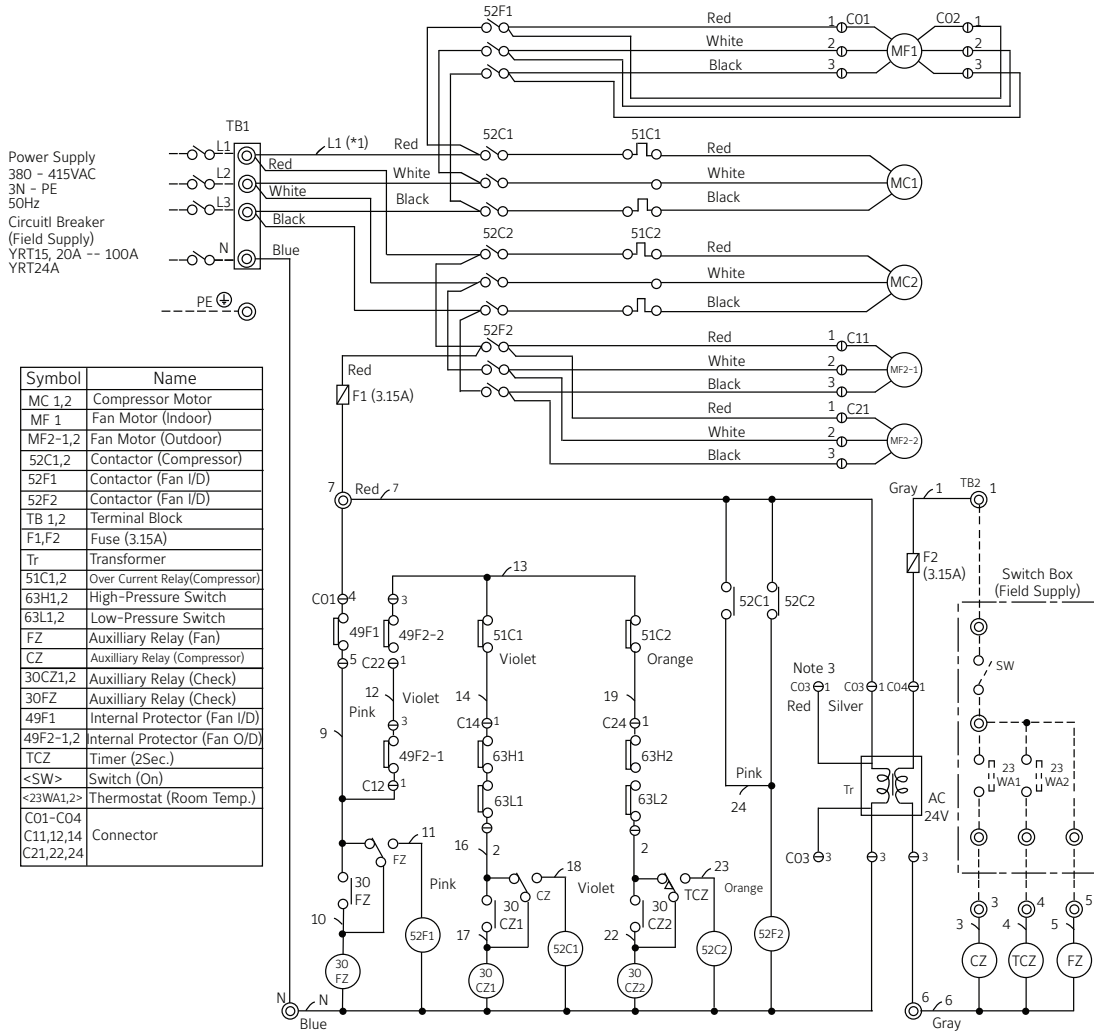

Fig 1. Control Box Layout

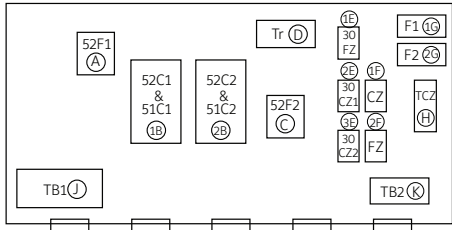
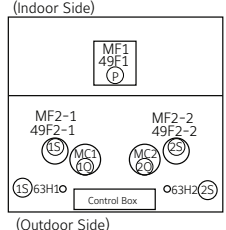
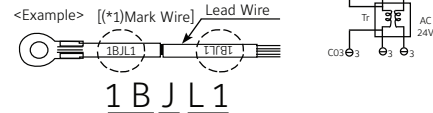

Fig 2. Unit Internal Layout



Note :

- The dotted lines show field wiring.
- The figure in the parenthesis show field supply parts.
- In case of power supply 380VAC model (YRT15, 20, 24ACY4M) Tr wiring. Change the connector connection of Tr, if 380VAC model is used for 400,415VAC and 400,415VAC model is used for 380VAC.
- Refer below example about wiring mark.



Caution :

- To protect compressor from abnormal current, over current relays <51C1,2> are installed. Therefore, do not change factory set value of over current relays.
- This timer <TCZ> installed because the power supply breaker may operate if two compressors start at the same time.
- Do not change factory set value of timer.

Controller Connection

Symbol	No.	Function	PAC-204RC (Option) Terminal No.
TB2	1	Power (Active)	24VAC(L)
	3,4	Cooling Operation	COMP1,2
	5	Fan Operation	FAN HI
	6	Power (Neutral)	24VAC(N)

Wiring Diagram

Model: YRT32A

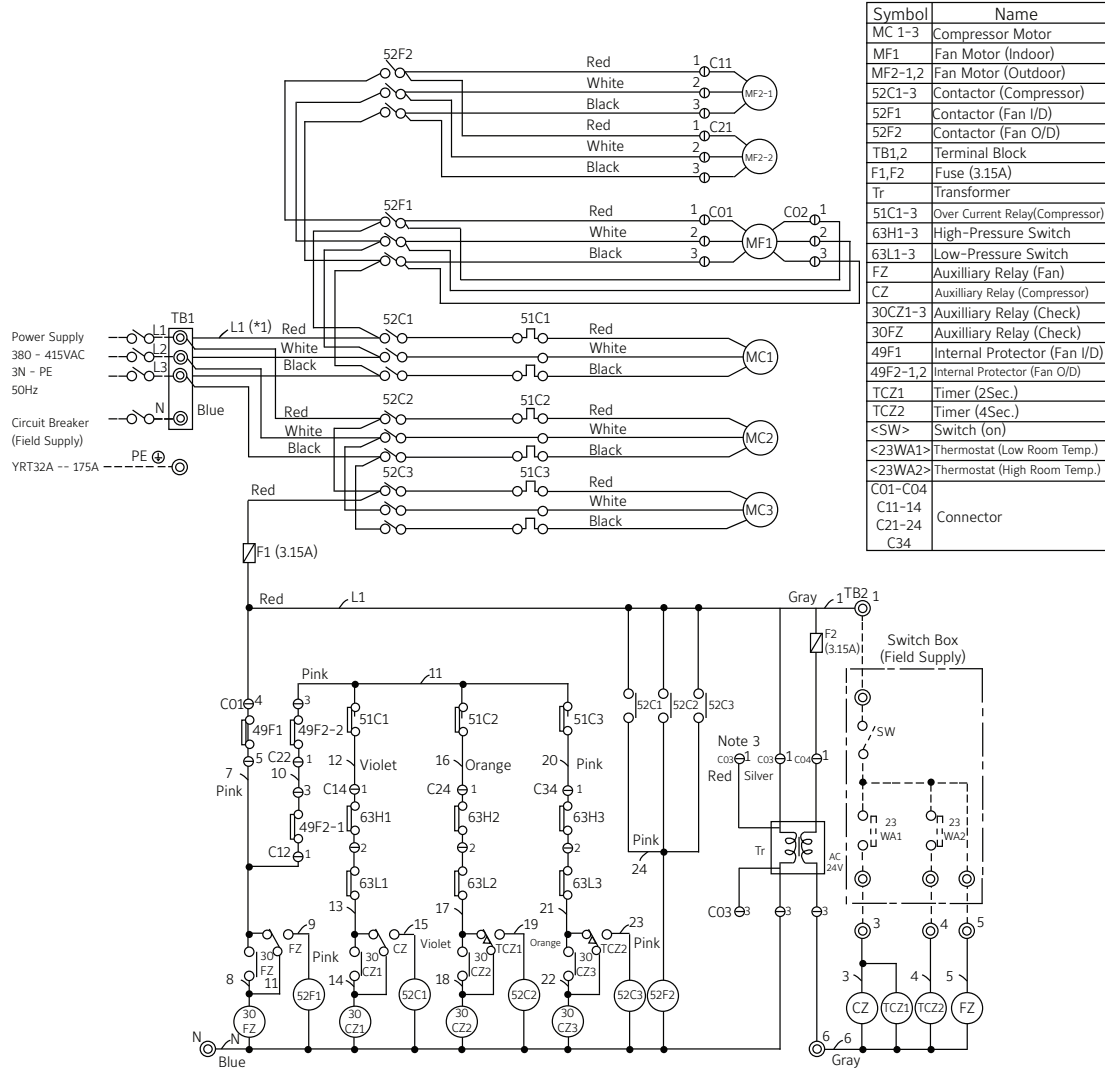

Symbol	Name
MC 1-3	Compressor Motor
MF1	Fan Motor (Indoor)
MF2-1,2	Fan Motor (Outdoor)
52C1-3	Contactors (Compressor)
52F1	Contactors (Fan I/D)
52F2	Contactors (Fan O/D)
TB1,2	Terminal Block
F1,F2	Fuse (3.15A)
Tr	Transformer
51C1-3	Over Current Relay(Compressor)
63H1-3	High-Pressure Switch
63L1-3	Low-Pressure Switch
FZ	Auxiliary Relay (Fan)
CZ	Auxiliary Relay (Compressor)
30CZ1-3	Auxiliary Relay (Check)
30FZ	Auxiliary Relay (Check)
49F1	Internal Protector (Fan I/D)
49F2-1,2	Internal Protector (Fan O/D)
TCZ1	Timer (2Sec.)
TCZ2	Timer (4Sec.)
<SW>	Switch (on)
<23WA1>	Thermostat (Low Room Temp.)
<23WA2>	Thermostat (High Room Temp.)
C01-C04 C11-14 C21-24 C34	Connector

Fig 1. Control Box Layout

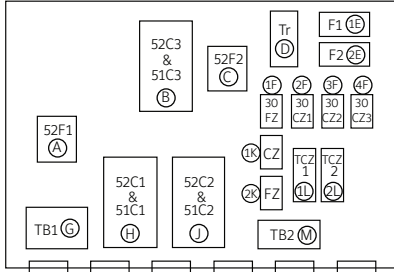
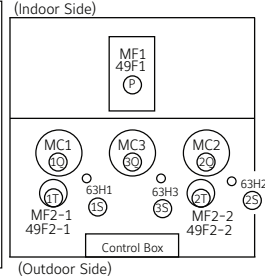
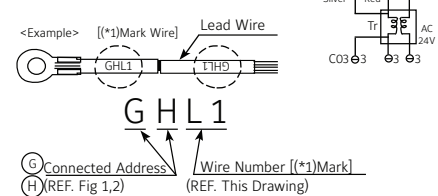

Fig 2. Unit Internal Layout



Note :

1. The dotted lines show field wiring.
2. The figure in the parenthesis show field supply parts.
3. In case of power supply 380VAC model (YRT32ACY4M) Tr wiring. Change the connector connection of Tr, if 380VAC model is used for 400,415VAC and 400,415VAC model is used for 380VAC.
4. Refer below example about wiring mark.



Controller Connection

Symbol	No.	Function	PAC-204RC (Option) Terminal No.
TB2	1	Power (Active)	24VAC(L)
	3,4	Cooling Operation	COMP1,2
	5	Fan Operation	FAN HI
	6	Power (Neutral)	24VAC(N)

Caution :

1. To protect compressor from abnormal current, over current relays <51C1,2,3> are installed. Therefore, do not change factory set value of over current relays.
2. This timer <TCZ1,2> installed because the power supply breaker may operate if three compressors start at the same time.
3. Do not change factory set value of timer.

Installation

All series of air conditioners are designed for outdoor installations and are to be placed on a slab or rooftop. However if the air conditioner is to be installed in a plant room, please contact your equipment supplier prior to installation.

Access for both service and installation must be provided to the compressors, control wiring and fans as shown below.

1. Space required around units

- Care must be taken to prevent recirculation of the condenser air.
To stabilize compressor, condensing pressures it is recommended that wherever possible the condenser air inlet side be faced away from prevailing winds.
- For rooftop installation, the type of mounting base depends on the roof construction. A built-up roof may not support the weight of the unit and so it may be necessary to support the unit by adding structural members below it.

- The units are equipped with hoisting plates for rigging and hoisting of the unit. The hoisting plates are located on the top of the unit. When hoisting the unit with a crane, spreader bars must be used to prevent damage to side panels by the supporting cables.

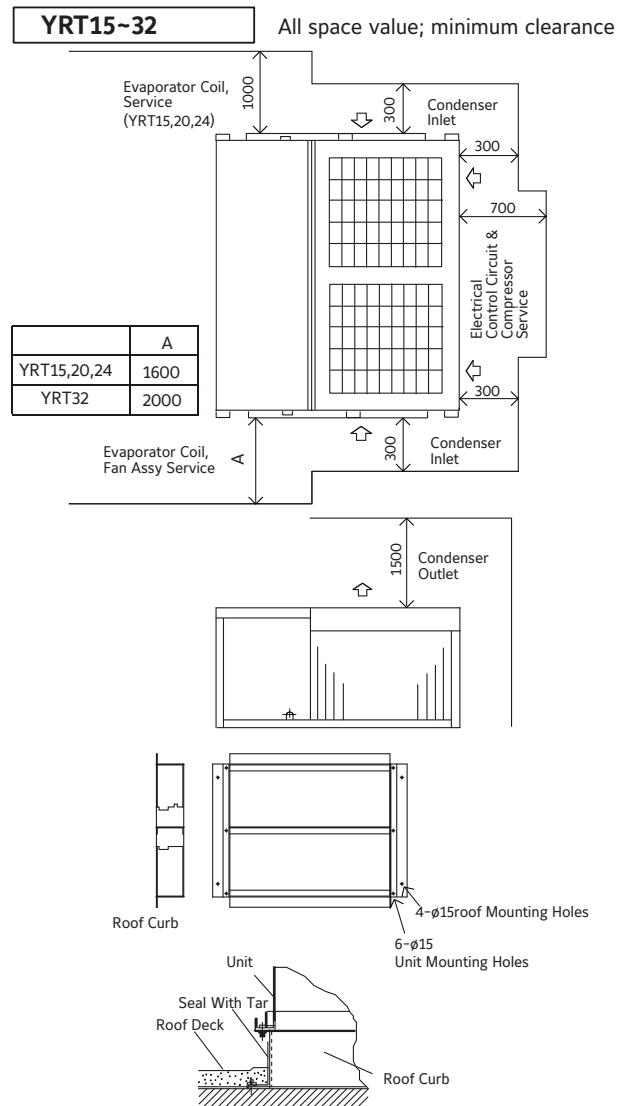
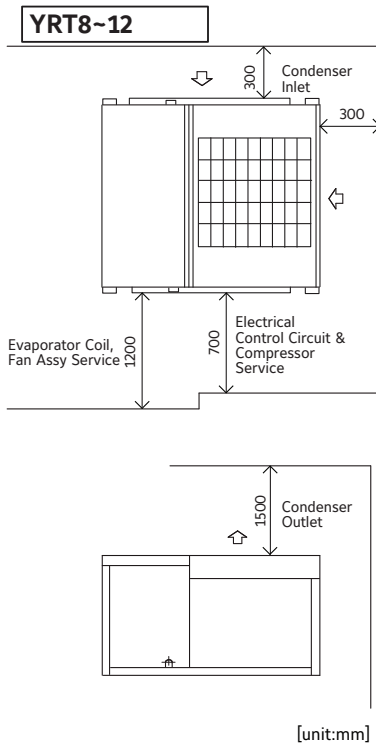

2. Installation of the unit

- The figure shows the use of the roof curb available for mounting these units.
- The curb should be sealed and fixed to the roof with weather stripping. A suggested means of sealing the unit and roof curb is shown below.

3. Duct construction

- Series YRT units are equipped with horizontal supply and return air openings. Duct connection to the unit should be made with duct flanges and secured directly to the air openings with flexible duct connectors to avoid abnormal noise transmission.
- For vertical air supply, a field supply plenum should be used. The figure below shows the recommended method for duct connection.
- To prevent air leakage, all duct seams should be taped. Ducts that run in air spaces that are not air-conditioned must be insulated and provided with a vapor barrier. Ducts exposed to the outside must be weather proofed. For quiet operation, we recommend that the insulation on the supply duct be placed inside, lining the duct.
- Where ducts from the outside enter a building, the duct openings in the building should be sealed with weather stripping to prevent rain, dust, sand, etc. from entering the building.
- Fans will not accept any external resistance to airflow. Hence, need to determine what provision is available if ductwork is to be fitted with external fans.
- Correctly sized filters must be fitted and there is no provision within the unit. However, the filters may be installed in the return air duct.

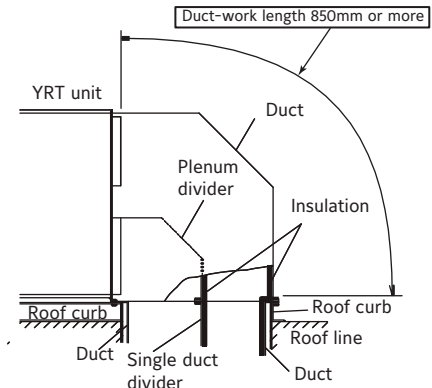

Duct connection with a vertical air plenum

4. Lifting method

When the unit is to be lifted and moved, attach ropes to the suspension plates (4 pcs) provided on the top of the unit. When the unit is lifted, the center of gravity tends to shift the unit to one side and so balance, as shown in the right figure, should be achieved. The angles at which the ropes suspend the unit should be at least 60° at the compressor end and at least 45° at the condenser end. Care should be taken to avoid contact with the main unit while carrying.

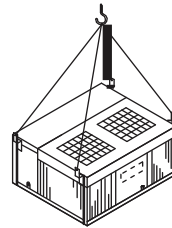

Hook as directly aligned over the center of gravity as possible.

5. Drain piping

- The condensate drain fitting (R 1) is provided. The drain pipe can be let out at the right or left side. Under standard specifications, it is let out at the left side and the right side is covered.
- The drain pipe must have a trap on the outside of the unit and must be installed at an incline for proper drainage, as shown on the right.
- To prevent condensate formation and leakage, provide the drain pipe with insulation to safeguard against sweating.
- Upon completion of the piping work, check that there is no leakage and that the water drains off properly.

The drain piping should have a drain trap.

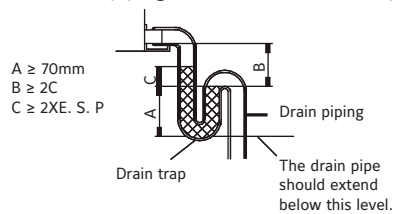

Note: ESP = External Static Pressure
Drain trap for condensate

6. Refrigerant charge

An additional charge is unnecessary, except for YRT32. The table below shows the amount of the charge when the unit is shipped.

Refrigerant charge per circuit (kg)	YRT8	YRT10	YRT12	YRT15	YRT20	YRT24	YRT32
YRT-ACY2 (R22)	4.0	5.9	5.7	2X4.5	2X5.9	2X5.7	3X3.5*
YRT-ACY4 (R407C)	4.5	5.9	5.7	2X4.8	2X5.9	2X5.7	3X3.5*

*Full Charge of YRT 32 is 3 x 6.3

7. Electrical wiring

a. Method for connecting electrical wire

Please consult with your power company before doing the wiring in the instructions.
The entire wiring diagram of unit.

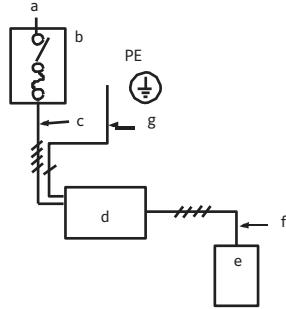

a.	Power Supply
b.	Main Switch/Fuse (Field Supply)
c.	Power Supply Wiring For Unit
d.	Unit
e.	Remote Controller/Thermostat (Field Supply)
f.	Connection Wiring For Unit / Remote Controller
g.	Earth

b. Electrical wiring

In case of using switch box (field supply), please set up wires as shown above.
Remove the panel on the right side (YRT8,10,12) or the rear side (YRT15, 20, 24, 32) of the unit and connect the units power supply wiring to the proper terminals in the control box.
Connect the wires on the basis of the following wiring diagram.
Mistake in wiring connection may damage the controller.

Caution : This controller can be damaged if wrong connection.

Construct the earth connection.

All electrical work must be carried out by a qualified electrical trades-person and in accordance with local supply authority requirements and associated regulations. The range of working voltage is within $\pm 10\%$ voltage of power supply. The unit is to be wired directly from an electrical distribution board either by a circuit breaker (preferred) or HRC fuse.

Fix power source wiring to control box by using buffer bushing for sensible force (PG connection or the like).
Connect control wiring to control terminal block through the knockout hole of control box using ordinary bushing.

NOTE: Earth wiring must be connected.

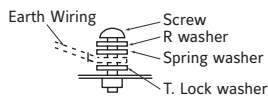

Control module of unit (YRT15,20,24)

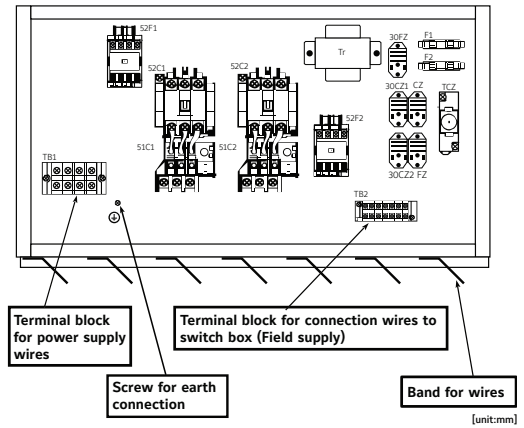

Control module of unit (YRT32)

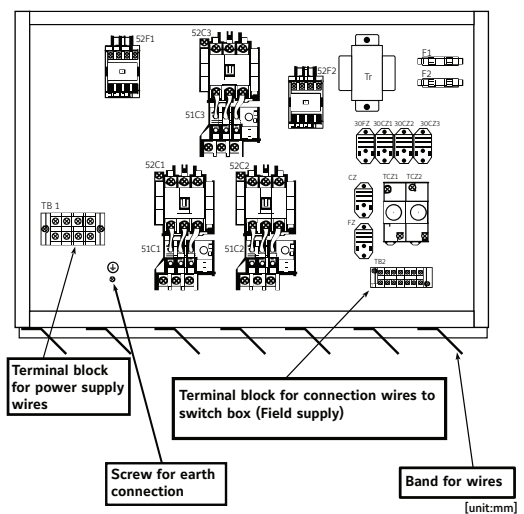

Control module of unit (YRT8,10,12)

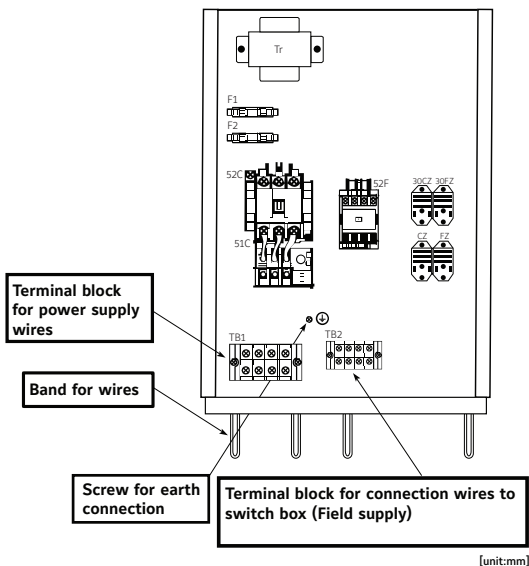

c. Wiring example (For metal piping)

	Power cable	Breaker capacity	Over current protection switch	Earth cable
YRT8	14mm ²	50A	50A	14mm ² over
YRT10	14mm ²	50A	50A	14mm ² over
YRT12	14mm ²	50A	50A	14mm ² over
YRT15	22mm ²	100A	100A	22mm ² over
YRT20	38mm ²	100A	100A	22mm ² over
YRT24	38mm ²	100A	100A	22mm ² over
YRT32	60mm ²	175A	175A	30mm ² over

The grounding wire must be the same diameter as the power cable wires. See Table above.

The selection of other capacities should be determined in accordance with the relevant standards.

d. Selecting earth leakage breaker (NV)

To select NF or NV instead of a combination of Class B fuse switch, use the following.

In the case of Class B fuse rated 15A.

	Fuse (class B)	Earth leakage breaker (with over-load protection)		
YRT8	50A	NV50-CP	50A	30mA 0.1s or less
YRT10	50A	NV50-CP	50A	30mA 0.1s or less
YRT12	50A	NV50-CP	50A	30mA 0.1s or less
YRT15	100A	NV100-CP	100A	100mA 0.1s or less
YRT20	100A	NV100-CP	100A	100mA 0.1s or less
YRT24	100A	NV100-CP	100A	100mA 0.1s or less
YRT32	175A	NV225-CP	175A	100mA 0.1s or less

See table above. The selection of other capacities should be determined in accordance with the relevant standards.

Note.

All electrical wiring must comply with local electrical authority regulations.

8. Before starting the trial run

After having installed the unit, check that:

- The unit is fixed securely.
- The unit is installed properly.
- The drain pipe is provided with a drain trap.
- The electrical wiring has been connected correctly and the terminal screws have been properly tightened.
- The duct work has been performed correctly.
- Before turning the unit on, measure the resistance between the terminals of the electrical parts and ground with a 500V megger and check that the value is at least 1.0M ohm.
If the measured value is below 1.0M ohm, do not operate the unit.
- **IMPORTANT** : Phase protector is installed in all units.
The unit does not run if there is wrong phase wiring of power supply.
Please reconfirm and modify wiring phase.
- Check that the fans are rotating in correct direction.
- Check whether there is refrigerant leakage, and slack power or transmission cable.
- Check the operation of high-pressure switch.
If the two lead wires of the outdoor unit fan motor are disconnected from the contactor and cooling is performed, the high-pressure switch should operate and stop the unit after 5 to 10 minutes.
Perform trial operation after completing above items.

Instructions For Use

1. Caution for use

Keep the following points in mind to safeguard against failures and break downs.

- For safety, confirm that the earth terminal has been connected to the earth wire correctly.
- Never block or cover the unit's intakes or outlets. It will reduce the unit's efficiency.
- To start the unit again turn the start switch on after 3 minutes have elapsed.
Repeatedly stopping and starting within 3 minutes can trip the fuse or power source switch.

2. Maintenance

For superior performance and lasting durability, please do not forget to conduct proper and regular maintenance.



Caution

For safety, turn the power source off before service work.

a. Cleaning of panel

Clean dirt of panel as follows.

Use a household neutral cleanser such as for dishes or vegetables.

Motion a soft cloth with the cleanser, then wipe lightly.

Next, wipe three or four times with another soft cloth moistened with water. Finally, wipe off all the remaining cleanser with a soft cloth.

Moisten a soft cloth with alcohol, then wipe off lightly. Isopropyl alcohol is sold at stores as reagents in small quantities.

Finger-marks

Grease

Adhesive

Paste

Neutral
Cleanser

Isopropyl
Alcohol

Note:

Alcohol is highly combustible. Take extreme care when handling. Also, do not use paint or adhesive thinner.

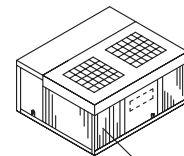

Heat exchanger

b. Cleaning the outdoor heat exchanger

If you use your air conditioner for prolonged periods, the outdoor heat exchanger will become dirty, impairing its function and reducing air conditioner's performance.

Consult your equipment supplier or air conditioning contractor on how to clean the heat exchanger.

c. When beginning to use air conditioner again

Please turn on the power supply after the following check is done and no abnormality is found.

It is confirmed that air inlet and outlet are not blocked.

It is confirmed that the earth connection line does not come off.

The earth connection line is installed firmly in the unit.

It is confirmed that there are neither lifting, blocking, nor bending about the drain-hose.

- It is confirmed to keep the controller OFF.
- The power supply switch is turned on.

d. When the air conditioner is not to be used for long time

If the air conditioner is not to be used for a long time due to a seasonal change, etc., please do the following work.

- The power supply switch is turned off.
If the power supply is kept on, electricity tons will be wasted.
Also, the accumulation of dust, etc., can result in fire.
- Filter, eliminator and drain pan are cleaned. Be sure to throw dust properly.
- Run it for 4-5 hours with the air blowing until the inside is completely dry.
Failing to do so can result in the growth of unhygienic, unhealthy mold in scattered areas throughout the room.

e. In case of failure

- Never remodel the air conditioner. Consult your dealer for any repair service. Improper repair work can result in water leakage, electric shock, fire, etc.
- If the poser breaker is frequently activated, get in touch with your dealer.
Leaving the unit as it is under such conditions can result in fire or failure.
- If the refrigeration gas blows out or leaks, stop the operation of the air conditioner.
- Thoroughly ventilate the room, and contact your dealer.
Leaving the unit as it is can result in accidents due to oxygen deficiency.

4. Transferring work, and construction

a. Transfer of installation

- When removing and reinstalling the air conditioner when you enlarge your home, remodel, or move, consult with your dealer in advance to calculate the cost of the professional engineering work required for transferring the installation.
- Please do not mix different types of refrigerant when you add the refrigerant (R-22 or R407C) during installation and the transferring.
- When moving or reinstalling the air conditioner, consult with your dealer.
Defective installation can result in electric shock, fire, etc.

b. Place for installation

Please do not use the unit in the following places.

- Place where a lot of oil (The machine oil is contained), moistures, and dust exist.
- Place where a lot of salinities such as beach districts exist.
- Place where sulphur gas, volatile gas, and corroded gas are filled.
- Place where acid solution is frequently used.
- Place where special spray is frequently used.
- Hot spring zone.
- Near to machine which generates high cycles. (e.g. high cycle welding machine etc.)
- Place where ventilation entrance of unit is blocked by snowfall.
- The unit must be installed on stable, level surface.

The main body might corrode when the unit is used in such a place, the refrigerant leak, the performance of the unit decrease remarkably, causing damage to parts of the unit.

c. Regarding electric work

- The electrical work must be undertaken by a person who is qualified as an electric engineer according to the (technical standard respecting electrical installation), (internal wiring rules), the installation and operation manual with the absolute use of exclusive circuits. The range of working voltage is within $\pm 10\%$ voltage of power supply.
- Please install a special power supply in the power supply.
- Please install the earth connection for the electric shock prevention.
- Never connect the grounding wire to a gas pipe, water pipe, arrester, or telephone grounding wires. For details, consult your dealer.
- In some types of installation sites, the installation of an earth leakage breaker is mandatory. For details, consult your dealer.
- The breaker and the fuse must use the correct capacity.

The main body might corrode when the unit is used in such a place, the refrigerant leak, the performance of the unit decrease remarkably, causing damage to parts of the unit.

d. Consideration of the noise

- Take sufficient measures against noise when installing the unit where noise level is critical.
- If any object is placed near the air outlet of the unit, decreased performance and increased noise will result. Avoid placing any obstacles adjacent to the air outlet.

e. Maintenance and inspection

- If the unit is used throughout several seasons, the heat exchanger can get dirty, reducing performance.
- Depending upon the conditions of usage, foul odors can be generated and drainage can deteriorate due to dust and dirt, etc.

Troubleshooting

Before you ask for repair service, check the following points:

Problem	Cause	Troubleshooting
Unit not running	Power failure	Press the [ON/OFF] button after power
	The power supply is turned OFF.	Turn the power supply ON.
	The fuse in the power supply is burnt.	Replace fuse.
	The earth leakage breaker is gone.	Put in the earth leakage breaker.
	The wiring phase of power supply is mistaken.	Modify the wiring phase of power supply.
Unit running but not cool.	Improper temperature adjustment.	Check the set temperature and inlet temperature on the liquid crystal display and adjust accordingly.
	The filter is filled with dust and dirt.	Clean up the filter.
	There are some obstacles at the air inlet or outlet of the units.	Remove.
	Windows or doors are open.	Close.
	Insufficient refrigerant charge.	Contact your installation contractor.
	The restart-preventing circuit is in operation for 3 minutes.	Wait for a while. (To protect the compressor, a 3-minute restart preventing circuit is built into the unit. Therefore, there are occasions when the compressor does not start running immediately. There are cases when it does not run for as long as 3 minutes.)
Fan runs but compressor does not run	The set temperature for thermostat is excessively high for cooling.	For temperature control, decrease the set temperature at cooling.
	The room temperature is excessively low for cooling.	Cannot be operated as it is out of temperature control range.
Compressor runs but stops immediately.	Air outlet or inlet is blocked.	Remove blocking matter.
Water or steam is discharged from the unit.	Air flow too high	It is not a breakdown. Please contact and consult your dealer.
	The drain pipe is clogged, therefore the drain water overflows.	Clear the drain pipe.

Exploded View And Parts List

YRT8,10,12A

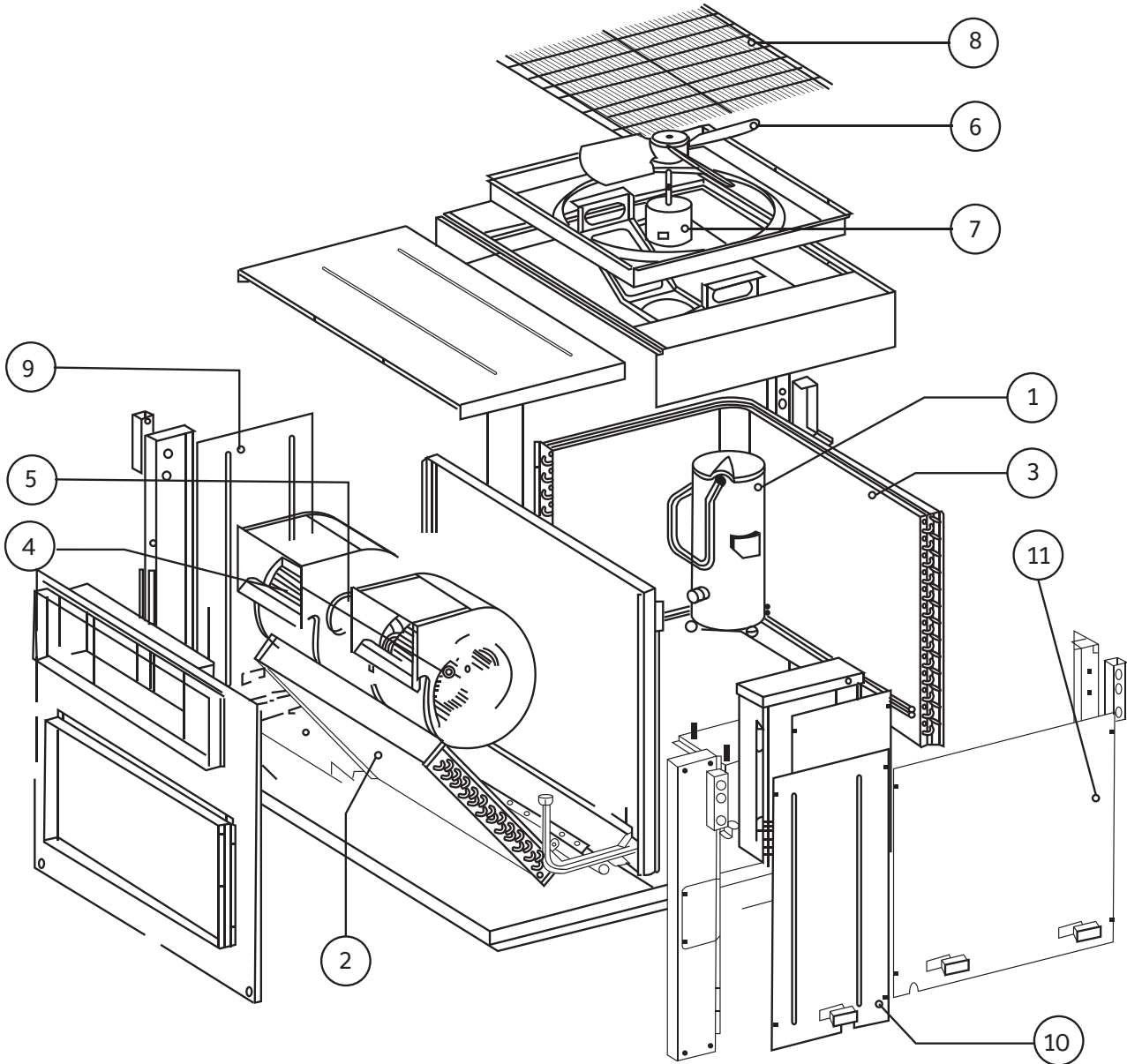

No	Description	Quantity		
		YRT8	YRT10	YRT12
1	Compressor	1	1	1
2	Coil Evaporator	1	1	1
3	Coil Condenser	1	1	1
4	Blower Indoor	2	2	2
5	Fan Motor Indoor	1	1	1
6	Blower Outdoor	1	1	1
7	Fan Motor Outdoor	1	1	1
8	Fan Guard	1	1	1
9	Side Panel, Left	1	1	1
10	Side Panel, Right	1	1	1
11	Service Panel	1	1	1

YRT15,20,24A

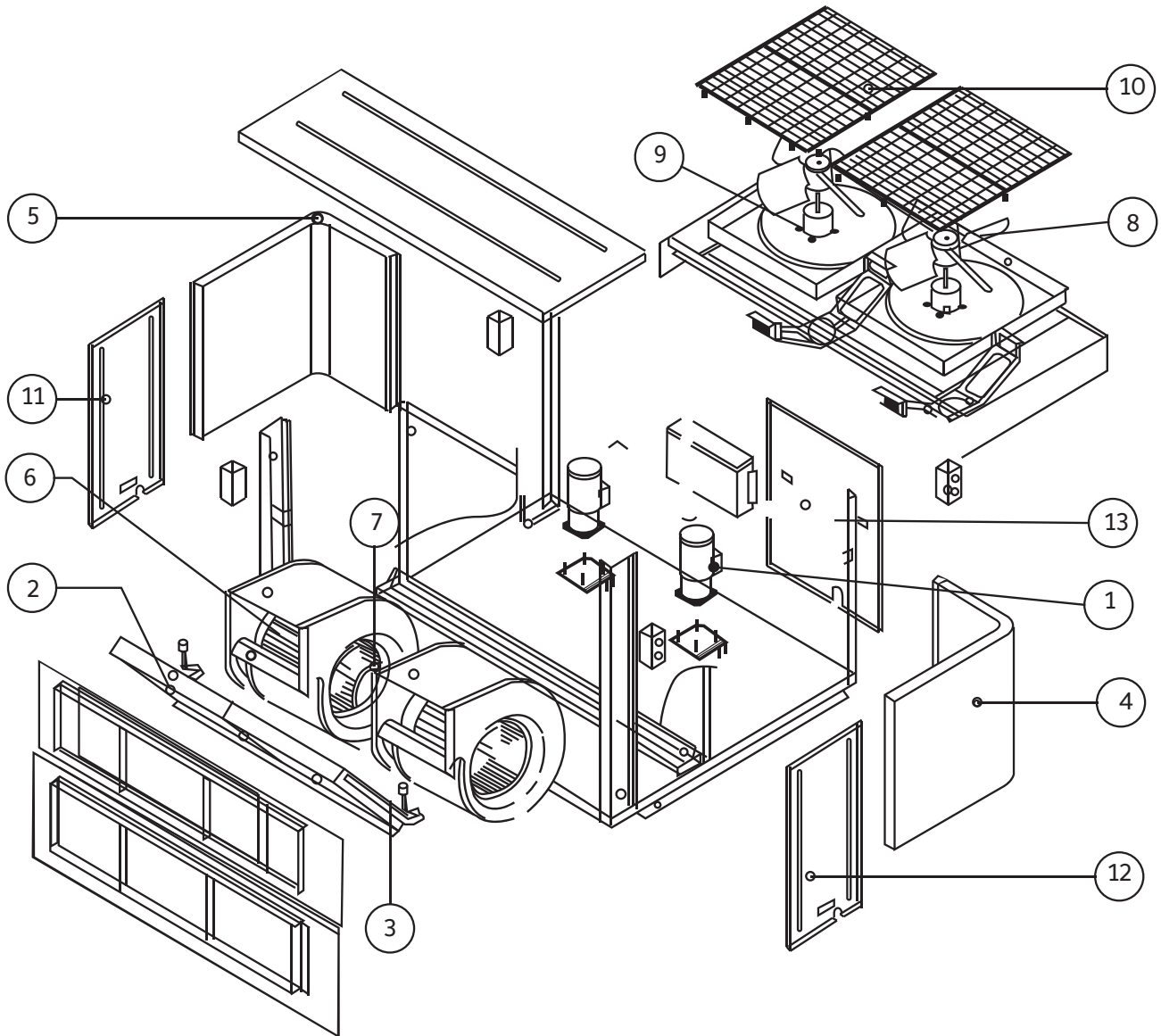

No	Description	Quantity		
		YRT15	YRT20	YRT24
1	Compressor	2	2	2
2	Coil Evaporator Left	1	1	1
3	Coil Evaporator Right	1	1	1
4	Coil Condenser Right	1	1	1
5	Coil Condenser Left	1	1	1
6	Blower Indoor	2	2	2
7	Fan Motor Indoor	1	1	1
8	Blower Outdoor	2	2	2
9	Fan Motor Outdoor	2	2	2
10	Fan Guard	2	2	2
11	Panel, Service L (In)	1	1	1
12	Panel, Service R (In)	1	1	1
13	Panel, Service (Out)	1	1	1

YRT32A

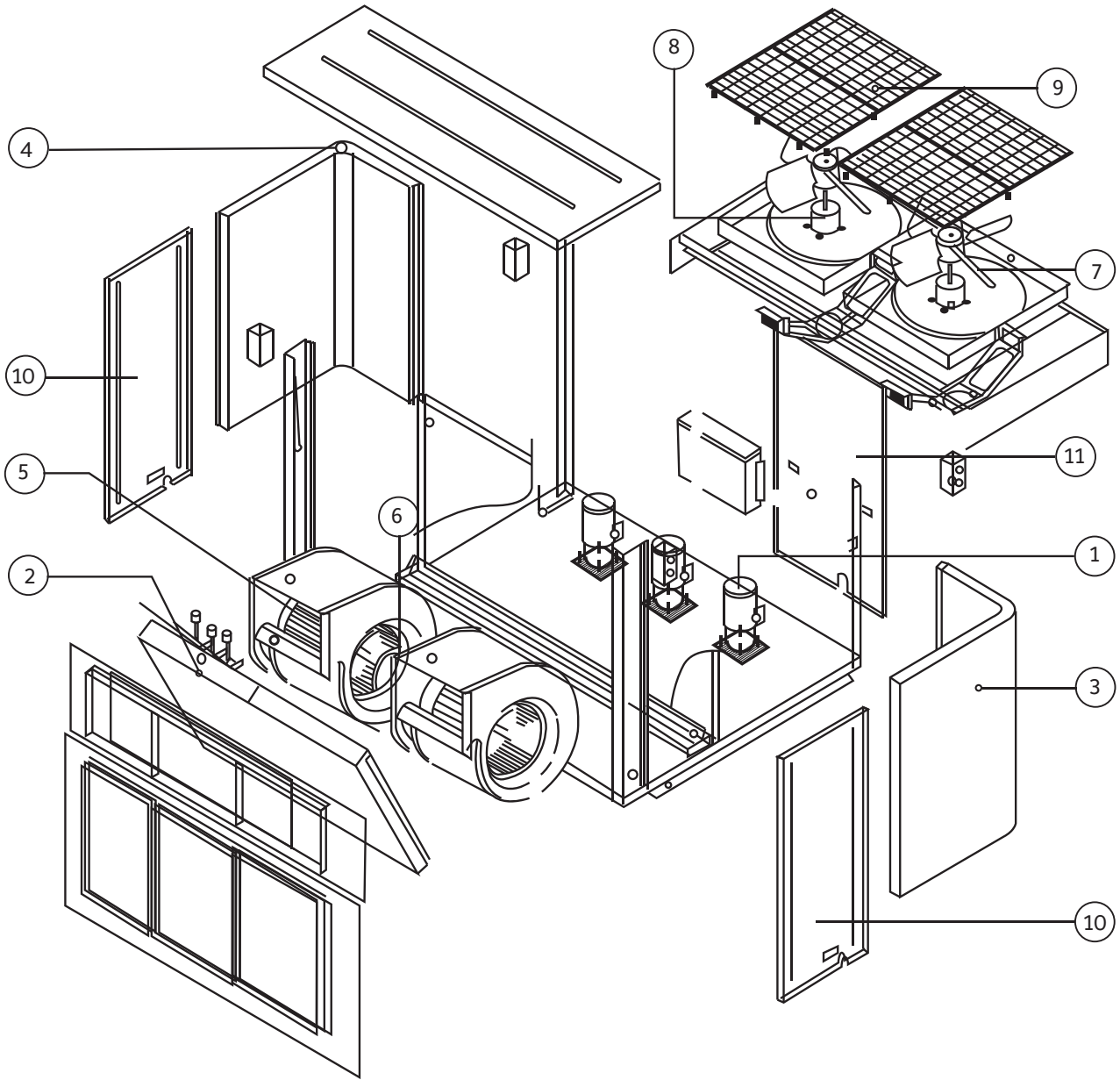

No	Description	Quantity (PCS)
1	Compressor	3
2	Coil Evaporator	1
3	Coil Condenser Right	1
4	Coil Condenser Left	1
5	Blower Indoor	2
6	Fan Motor Indoor	1
7	Blower Outdoor	2
8	Fan Motor Outdoor	2
9	Fan Guard	2
10	Panel, Service Indoor	2
11	Panel, Service Outdoor	1

Conversion Table

Distance

cm	m	km	in	ft
1	0.01	0.00001	0.3937	0.0328
100	1	0.001	39.37	3.2808
100,000	1,000	1	39,370	3,280.8
2.54	0.0254	0.0000254	1	0.08333
30.48	0.3048	0.0003048	12	1

Area

in ²	ft ²	m ²	cm ²
1	0.00694	0.0006452	6.452
144	1	0.093	929.03
1,550.06	10.764	1	10,000
0.155	0.001076	0.0001	1

Cooling Capacity

Btu/hr	MBH	Kcal/hr	kW	Ton
1	0.001	0.252	0.000293	0.000083
1,000	1	252	0.293	0.0833
3,968	0.004	1	0.001162	0.000331
3,412	3.412	860.04	1	0.284
12,000	12	3,024	3.52	1

Fouling Factor

English I-P	Equivalent ST Metric
ft ² °Fhr/Btu	m ² k/kW
0.0001	0.018
0.00025	0.044
0.0005	0.088
0.00075	1.132

Flow Rate

l/s	m ³ /hr	m ³ /s	US GPM	cfm
1	3.6	0.001	15.85	2.119
0.278	1	0.000278	4.403	0.588
1,000	3,600	1	15,850	2,119
0.063	0.227	0.000063	1	0.1337
0.472	1.7	0.000472	7.481	1

Temperature

$^{\circ}\text{F} = (1.8 \times ^{\circ}\text{C}) + 32$	
$^{\circ}\text{C} = (^{\circ}\text{F} - 32) / 1.8$	
°F	°C
100	37.77
32	0

Pressure

psi	kg/cm ²	w.g.		Pascal
		in	ft	Pa
1	0.07	27.7	2.309	6,900
0.0361	0.002538	1	0.083	284.84
0.000145	0.0000102	0.004	0.0003349	1

Volume

l	m ³	US Gallon	ft ³
1	0.001	0.264	0.0353
3.785	0.003785	1	0.134
28.315	0.028	7.48	1

Weight

kg	lb	Ton
1	2.2046	0.000984
0.4536	1	0.000446
1,016.3	2240.45	1

Velocity

fps	m/s	fp
1	0.305	60
3.281	1	196.6
0.017	0.005	1

Density

kg/m ³	lb/ft ³
1	0.06243
16.017	1

Head Office:

YORK (MALAYSIA) SALES & SERVICE SDN. BHD. (168496-T)

Bangunan THK, Suite 2.1, 2nd Floor,
No.2A, Jalan 243, Section 51A,
46100 Petaling Jaya, Selangor Darul Ehsan, Malaysia.
Tel: 03-7628 4100 Fax: 03-7628 4101

Branches:

Penang Branch

Tel: 04-397 0213 Fax: 04-397 2045

Kota Kinabalu Branch

Tel: 088-448 350 Fax: 088-448 352

Johor Bahru Branch

Tel: 07-354 9878 Fax: 07-354 9871

Kuching Branch

Tel: 082-553 100 Fax: 082-553 200

Customer Care Centre: 1800 – 88 – YORK (9675)

Website: www.york.com/my

Authorized Dealer

